

Favola T.

Icona di ieri,
rivoluzione
di oggi.

*Yesterday's icon,
today's revolution.*



Favola T.

Confezionatrici sottovuoto a campana

Chamber vacuum packaging machines

Machines sous vide à cloche

Kammer-Vakuuierer

Envasadoras al vacío de campana

Codice Code	Modello Model
1410V371	Favola T. 315/8
1410V372	Favola T. 315/20
1410V374	Favola T. 415/20
1410V375	Favola T. 415/25
1410V376	Favola T. 500/25
1410V377	Favola T. 560
1410V378	Favola T. 560 RAPIDA
1410V379	Favola T. 71060
1410V380	Favola T. 71100
1410V381	Favola T. 84100
1410V382	Favola T. 84160

FAVTP10B pompa/pump BUSCH 10 m³/h
315/8

FAVTP20B pompa/pump BUSCH 20 m³/h
315/20 - 415/20

FAVTP63B pompa/pump BUSCH 63 m³/h
560 - 71060



Caratteristiche e vantaggi

- Touch screen da 5", antigraffio e impermeabile
- Funzioni: confezionamento fino al 99% di vuoto, con funzione extravuoto fino a 9 secondi
- Programmi per il confezionamento dei liquidi, sgasatura, marinatura e ATM
- Di serie con Soft-Air elettronico/manuale e barra saldante con doppia piattina bombata
- Con deumidificazione e sensore vuoto assoluto
- Massima sicurezza con il countdown manutenzione

Characteristics and advantages

- 5" Touch screen display, scratch-resistant and waterproof
- Functions: packaging up to 99% vacuum, with possibility of extra vacuum packaging (up to 9 seconds)
- Programs: liquid packaging, air bubbles removal, marination, and MAP packaging
- Manual/electronic Soft-Air and sealing bar with double convex sealing wire included
- With dehumidification and full vacuum sensor
- Maximum safety with a maintenance countdown

Caractéristiques et avantages

- Écran tactile de 5" résistant aux rayures et étanche
- Fonctions : conditionnement jusqu'à 99% de vide avec possibilité de conditionnement extra vide (jusqu'à 9 secondes)
- Programmes : emballage liquide, dégazage, marinage et emballage MAP
- Avec Soft-Air manuel/électronique et barre de soudure avec double fil de soudure de serie
- Avec déshumidification et capteur de vide absolu
- Sécurité maximale avec le compte à rebours de maintenance

Merkmale und Vorteile

- 5-Zoll Touch screen, kratzfestes und wasserabweisendes Display
- Funktionen: Verpacken bis zu 99% Vakuum mit Extra- Vakuum (bis zu 9 Sekunden)
- Programme: Vakuumieren, Flüssigkeiten vakuumieren, Luft-Absaugung, Marinieren und MAP-Packaging
- Inklusive manuelle/elektronische Soft-Air Funktion und Schweißbalken mit Doppelschweißnaht
- Mit Entfeuchtungsprogramm und absoluten Vakuum-Sensor
- Maximale Sicherheit mit dem Wartungscountdown

Características y ventajas

- Pantalla táctil de 5", resistente a los arañazos y al agua
- Funciones: envasado al 99% de vacío, con posibilidad de envasado al vacío extra (hasta 9 segundos)
- Programas: envasado de líquidos, desgasificación, marinado y envasado MAP
- Con Soft-Air manual/electrónico y barra soldadora con cable de doble soldadura convexa de serie
- Con deshumidificación y sensor de vacío absoluto
- Máxima seguridad con cuenta atrás de mantenimiento

Scheda tecnica e caratteristiche

Technical details and features
Fiche technique et caractéristiques
Technische Details und Merkmale
Detalles técnicos y características

99 programmi memorizzabili

- 1 - 50 | Programmi standard
- 51 - 75 | Programmi di sgasatura
- 76 - 99 | Programmi infusione/marinatura



Up to 99 storable programs

- 1 - 50 | Standards programs
- 51 - 75 | Air bubbles removal programs
- 76 - 99 | Infusion/marination programs

Bis zu 99 speicherbare Programme

- 1 - 50 | Standard Programm
- 51 - 75 | Luftabsaugung Programm
- 76 - 99 | Infusion/Marinade Programm

Jusqu'à 99 programmes mémorisables

- 1 - 50 | Programmes standard
- 51 - 75 | Programmes de dégazage
- 76 - 99 | Programmes d'infusion/marinage

Hasta 99 programas almacenables

- 1 - 50 | Programas estándar
- 51 - 75 | Programas de desgasificación
- 76 - 99 | Programas de infusión/marinado

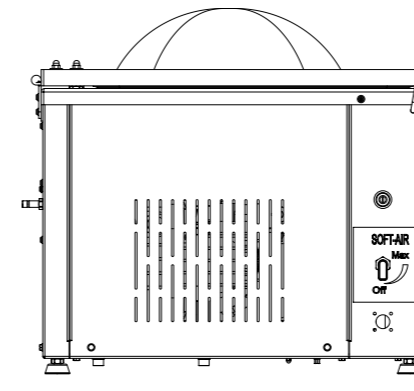

PROFONDITÀ DEPTH PROFONDEUR TIEFE PROFUNDIDAD

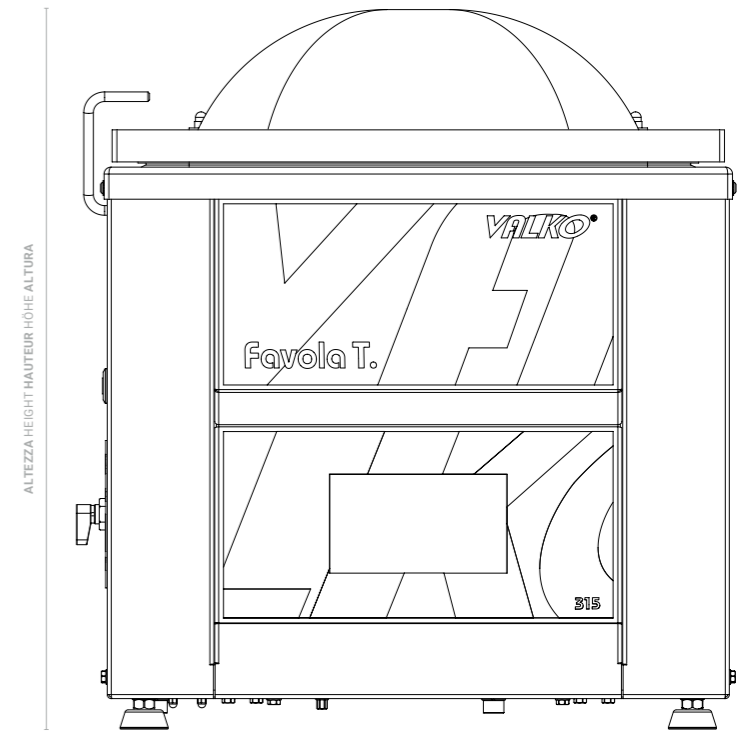
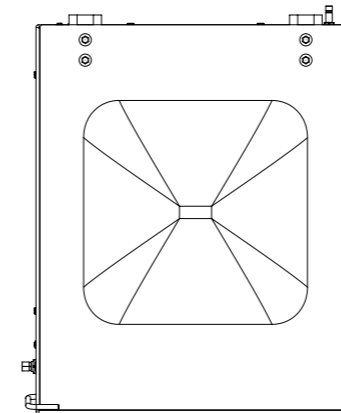

ALTEZZA HEIGHT HAUTEUR HOHE ALTURA

LARGHEZZA WIDTH LARGEUR BREITE ANCHURA

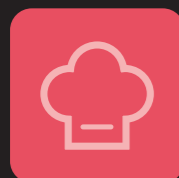

Programmi Professional
Professional Programs
Programmes Professionnels
Professional Programme
Programas Profesionales



Deumidificazione
Dehumidification
Déshumidification
Entfeuchtung
Deshumidificación



Sgasatura
Air bubbles removal
Dégazage
Luftabsaugung
Desgasificación



Manutenzione
Maintenance
Entretien
Wartung
Manutención



Marinatura e infusione
Marination and infusion
Marinage et infusion
Marinade und Infusion
Marinado y infusión



Impostazioni
Settings
Paramètres
Einstellungen
Ajustes

Modello Modèle Modell Modelo	Larghezza Width Largeur Breite Anchura	Profondità Depth Profondeur Tiefe Profundidad	Altezza Height Hauteur Höhe Altura	L x P x A camera Chamber W x D x H L x P x H chambre B x T x H Kammer A x P x A cámara	Barra saldante Sealing bar Barre de soudure Schweißbalken Barra soldadora	Pompa vuoto Vacuum pump Pompe à vide Vakuumpumpe Bomba vacío	Tensione Voltage Tension Spannung Voltaje	Potenza Power Puissance Leistung Potencia	Peso Weight Poids Gewicht Peso
Favola T. 315/8	412 mm	516 mm	449 mm	322 x 365 x 160 mm	315 mm	8 m³/h	230V~	900 W	47 Kg
Favola T. 315/20	412 mm	516 mm	449 mm	322 x 365 x 160 mm	315 mm	20 m³/h	230V~	900 W	47 Kg
Favola T. 415/20	512 mm	654 mm	517 mm	422 x 503 x 220 mm	415 mm	20 m³/h	230V~	1100 W	72 Kg
Favola T. 415/25	512 mm	654 mm	517 mm	422 x 503 x 220 mm	415 mm	25 m³/h	230V~	1100 W	72 Kg
Favola T. 500/25	595 mm	625 mm	517 mm	506 x 488 x 220 mm	500 mm	25 m³/h	230V~	1100 W	77 Kg
Favola T. 560	576 mm	725 mm	900 mm	506 x 558 x 265 mm	500 mm	60 m³/h	230V 3~ 400V 3N~	2000 W	132 Kg
Favola T. 560 RAPIDA	576 mm	725 mm	900 mm	506 x 558 x 215 mm	2x500 mm	60 m³/h		2000 W	142 Kg
Favola T. 71060	790 mm	725 mm	900 mm	720 x 558 x 265 mm	710+500 mm	60 m³/h	230V 3~ 400V 3N~	2000 W	165 Kg
Favola T. 71100	790 mm	725 mm	900 mm	720 x 558 x 265 mm	710+500 mm	100 m³/h		2200 W	175 Kg
Favola T. 84100	910 mm	725 mm	900 mm	846 x 558 x 265 mm	840+500 mm	100 m³/h		2200 W	190 Kg
Favola T. 84160	910 mm	725 mm	900 mm	846 x 558 x 265 mm	840+500 mm	160 m³/h		4200 W	222 Kg

Accessori

Optionals
Accessoires
Zubehör
Accesorios

Favola T.



Dispositivo fissaggio coperchio

Lid fastener
Dispositif de blocage du couvercle
Deckel-Fixierung
Dispositivo fijación tapa

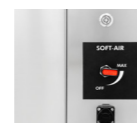

Soft-Air

Soft-Air
Soft-Air
Soft-Air
Soft-Air



Industry 4.0, modulo hardware Wi-Fi

Industry 4.0, additional Wi-Fi hardware
Industry 4.0, module matériel Wi-Fi
Industry 4.0, Zusätzliches Hardwaremodul Wi-Fi
Industry 4.0, módulo de hardware Wi-Fi

FAVT-IND40



Salvataggio dati su Cloud, canone annuo

Cloud Storage, annual fee
Sauvegarde des données sur le Cloud,
cotisation annuelle
Cloud Datenspeicher, Jahresgebühr
Almacenamiento de datos en el Cloud, cuota anual

000CLOUD



Unità iniezione gas inerte

Inert gas injection unit
Dispositif d'injection de gaz inerte
Begasungseinheit
Unidad inyección de gas inerte

1408V137 - 315

1408V138 - 415 / 500

1408V143 - 560 / 710 / 840



Piano inclinato per prodotti liquidi

Inclined plane for liquid products
Plan incliné pour produits liquides
Schrägeinsatz für flüssige Produkte
Plano inclinado para líquidos

1408V017 - 315

1408V018 - 415

1408V019 - 500 / 560

Barre saldanti

Sealing bar
Barres de soudure
Schweißbalken
Barras soldadoras



Maniglia sonda per vuoto esterno

Handle with probe for external vacuum
Poignée permettant de faire le vide à l'extérieur
Sonde für externes Vakuumieren
Sonda para vacío externo

1408V074 - 315 / 415 / 500



Valvola di blocco

Safety vane
Électrovanne de sécurité
Sicherheits-Absperrventil
Válvula de bloqueo

1408V088 - 560 / 710 / 840



T.Cube - stampante per etichetta adesiva

Label printer with adhesive paper
Imprimante pour étiquette adhésive
Etikettendrucker mit selbstklebenden Papier
Impresora para etiquetas adhesivas

1408V141



Rotolo carta adesiva (5pz)

Adhesive paper roll (5 pcs)
Rouleau de papier adhésif (5 pcs)
Etikettierolle, selbstklebend (5 St)
Rollo de papel adhesivo (5 pzs)

10140001



Supporto per stampante T.Cube

T.Cube printer stand
Support pour imprimante T.Cube
Halterung für T.Cube-Drucker
Soporte para impresora T.Cube

1408V144



Cavalletti smontabili in acciaio inox

Demountable stainless steel stands
Chariots démontables en acier inox
Edelstahl-Untergestelle
Caballetes desmontables en acero inox

1410V032 - 315

1410V033 - 415

1410V005 - 500

Modello Model	Set 1	Set 2	Set 3	Set 3+	Set 4
Favola T. 415	1408V053				
Favola T. 500	1408V021				
Favola T. 560	1408V054	1408V082	1408V057	1408V096	
Favola T. 710	1408V058	1408V060	1408V096		1408V061
Favola T. 840	1408V059	1408V060	1408V096		



Via Berlino, 1 - 24040 Bottanuco
Bergamo, Italy

tel +39.035.4992010
fax +39.035.4992015

info@valko.com
www.valko.com

VALKO is a registered trademark owned by CB srl