

VALKO[®]
SINCE 1995

Kuoco plus

Dove
l'essenziale
incontra
l'eccellenza.

*Where the essential
meets excellence.*



Kuoco plus

Codice Code Modello Model

1410V384 Kuoco plus



Altezza min. vasca 180 mm
Min. height of the tank 180 mm
Hauteur min. récipient 180 mm
Mindesthöhe des Behälters 180 mm
Altura min. del contenedor 180 mm



Capacità 20 L
Capacity 20 L
Capacité 20 L
Kapazität 20 L
Capacidad 20 L



Capacità carico di cottura 10 Kg
Cooking load capacity 10 Kg
Capacité de chargement de cuisson 10 Kg
Kapazität des Garvolumens 10 Kg
Capacidad de cocción 10 Kg

Apparecchio per cottura sottovuoto

Sous vide immersion cooker
Équipement pour la cuisson sous vide
Sous Vide-Garer
Aparato para la cocción al vacío

Caratteristiche e vantaggi

- Con nuovo schermo da 4"
- 20 programmi personalizzabili con timer
- Circolazione orizzontale dell'acqua
- Modalità manuale per un uso più esperto
- Basso consumo energetico (2 kW)
- Sensore della temperatura ad alta precisione 1/10°C

Characteristics and advantages

- With new 4" screen
- 20 customizable programs with timer
- Horizontal water circulation
- Manual mode for advanced use
- Low energy consumption (2 kW)
- High-precision temperature sensor 1/10°C

Caractéristiques et avantages

- Avec nouvel écran de 4 pouces
- 20 programmes à personnaliser avec timer
- Circulation horizontale de l'eau
- Mode manuel pour une utilisation avancée
- Faible consommation d'énergie (2 kW)
- Capteur de température haute précision 1/10°C

Merkmale und Vorteile

- Mit neuem 4-Zoll Screen
- 20 individuell gestaltbare Programme
- Horizontaler Wasserzirkulation
- Manueller Modus für erfahrene Anwender
- Geringer Energieverbrauch (2 kW)
- Hochpräziser Temperatursensor 1/10°C

Características y ventajas

- Con una nueva pantalla de 4"
- 20 programas personalizables con temporizador
- Circulación de agua horizontal
- Modo manual para un uso más avanzado
- Bajo gasto energético (2 kW)
- Sensor de temperatura de alta precisión 1/10°C

Dove l'essenziale incontra l'eccellenza

Where the essential meets excellence
Là où l'essentiel rencontre l'excellence
Wo das Wesentliche auf Exzellenz trifft
Donde lo esencial se encuentra con la excelencia

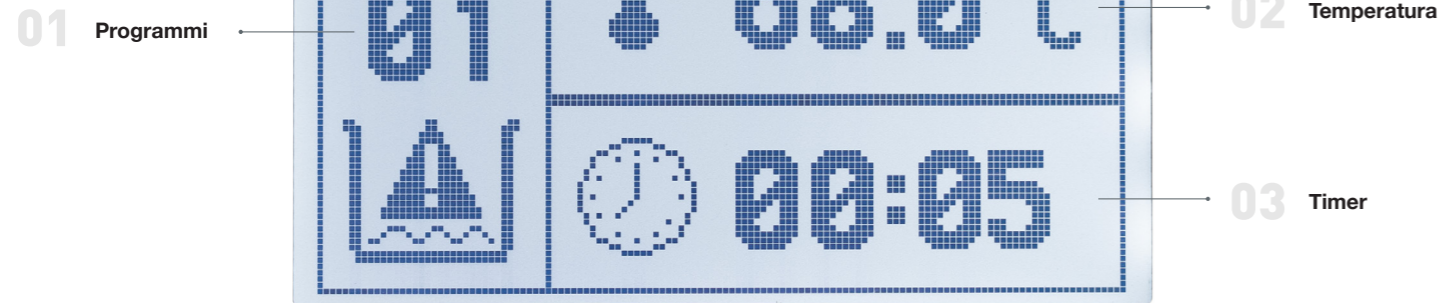

1. Programs
2. Temperature
3. Timer

1. Programmes
2. Température
3. Timer

1. Programme
2. Temperatur
3. Timer

1. Programas
2. Temperatura
3. Temporizador

La cottura delicata a bassa temperatura

- Esaltazione dei sapori
- Minor calo peso
- Migliore organizzazione dello stoccaggio
- Gestione dei cali e dei picchi di lavoro

Gentle cooking at low temperature

- Brings out flavours
- Lower food mass loss
- Better storage organization
- Better management of workload peaks and troughs

La cuisson délicate à basse température

- Exaltation des saveurs
- Moins de perte de poids
- Meilleure organisation du stockage
- Gestion des baisses et pics de travail

Schonendes Garen bei niedriger Temperatur

- Verstärkung der Aromen
- Weniger Gewichtsverlust
- Bessere Organisation der Lebensmittel-Lagerung
- Effizientes Lebensmittelmanagement bei hoher und niedriger Nachfrage

La cocción suave a baja temperatura

- Exaltación de los sabores
- Menor pérdida de peso
- Mejor organización del almacenamiento
- Gestión de bajadas y picos de trabajo



Accessori

Optionals
Accessoires
Zubehör
Accesorios



Bacinella Gastronorm inox

Gastronorm tray
Bac Gastronorm
Gastronorm Behälter
Contenedor Gastronorm

10040061 - GN1/1



Coperchio isolante per bacinella Gastronorm

Insulating lid for Gastronorm tray
Couvercle isolant pour bac Gastronorm
Isolierender Deckel für Gastronorm Behälter
Tapa aislante para contenedor Gastronorm

1408V136 - GN1/1



Divisorio per bacinella

Dividing grid for tray
Grille de séparation pour bac
Trenngitter für Garbehälter
Divisorio para contenedor

0401VB25



Sonda al cuore con ago, termocoppia T

Core probe needle, T type thermocouple
Aiguille de la sonde au coeur, thermocouple de type T
Kerntemperaturfühler mit Nadel, T-Thermoelement
Sonda al corazón con aguja, termopar tipo T

09040017



Eko Cleaner, anticalcare e disincrostante (6 flaconi x 1 L)

Eko Cleaner, descaler and degreaser (6 x 1 L)
Eko Cleaner, détartrage et décroûillage (6 x 1L)
Eko Cleaner, Entkalker und Entkruster (6 x 1L)
Eko Cleaner, desincrustante y desengrasante (6 x 1 L)

15030125

Scheda tecnica e caratteristiche

Technical details and features
Fiche technique et caractéristiques
Technische Details und Merkmale
Detalles técnicos y características

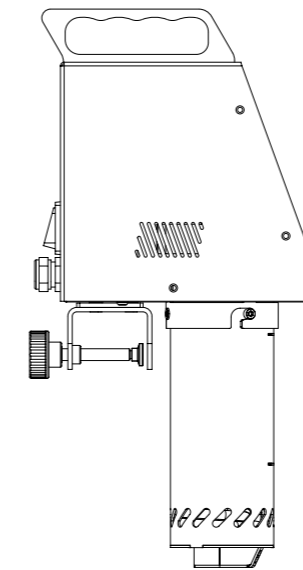

PROFONDITÀ DEPTH PROFONDEUR TIEFE PROFUNDIDAD

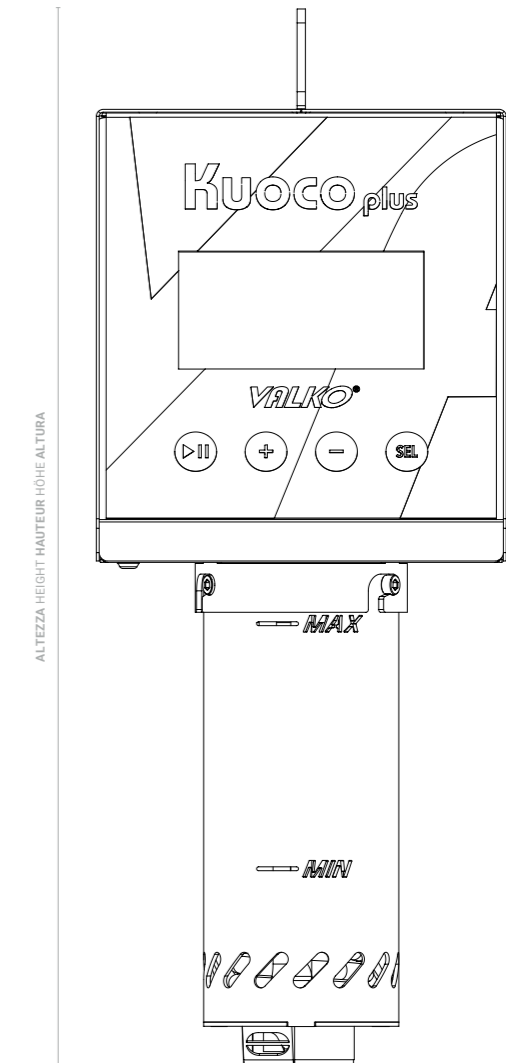
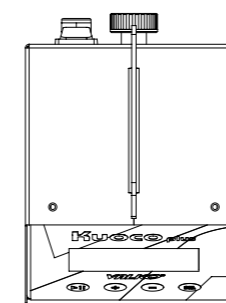

ALTEZZA HEIGHT HAUTEUR HOHE ALTURA

LARGHEZZA WIDTH LARGEUR BREITE ANCHURA

Modello Modèle Modell Modelo	Larghezza Width Largeur Breite Anchura	Profondità Depth Profondeur Tiefe Profundidad	Altezza Height Hauteur Höhe Altura	Temperatura di lavoro Working temperature range Température de travail Temperaturbereich Rango de temperatura de trabajo	Tensione Voltage Tension Spannung Voltaje	Potenza Power Puissance Leistung Potencia	Peso Weight Poids Gewicht Peso
KUOCO plus	147 mm	195 mm	380 mm	≤ 95°C	230V~	2100 W	4,1 Kg



Via Berlino, 1 - 24040 Bottanuco
Bergamo, Italy

tel +39.035.4992010
fax +39.035.4992015

info@valko.com
www.valko.com

VALKO is a registered trademark owned by CB srl